

## TEMPEST SEALED BOX APPLICATIONS

A technical paper related to the Tempest subwoofer



## 1 General Driver Description

Tempest is a subwoofer driver from Adire Audio. Tempest features a very long throw, low distortion design tailored to high SPL applications. For more information about Tempest, please see the Tempest White Paper.

## 2 General Application Notes

### 2.1 Power Amplifier Selection

At first glance, Tempest would seem to indicate a need for a 750W amplifier, since that's the power rating of the driver. However, this is not the case. Very good results can be achieved with Tempest running from as little as 40W per channel. Even smaller amplifiers (10WPC) can result in a musically satisfying experience. It really depends upon your tastes and the capabilities of the loudspeakers paired with Tempest.

The 750W rating of Tempest is just that: a maximum power rating. This is the peak amount of power that can be dissipated in Tempest over the long term. Realize that this level of power would yield an in-room output in the 120 dB SPL range; this level is well beyond the typical continuous home listening environment.

However, assuming a source peak-to-average ratio of 25 dB (such as is typical for modern music, FM broadcasts, and most soundtracks), listening at normal levels (80 dB SPL) would require peaks of 105 dB SPL. This peak level requires 17.5 dBW, or 56.2W of amplifier power. As such, most home receivers capable of 100W per channel performance will be quite suitable for use with Tempest.

We do realize that such listening levels (80 dB SPL nominal) are not for everyone. Some individuals will listen to Tempest at higher levels. The 750W rating is intended to allow for those who enjoy musical peaks up to and beyond 120 dB SPL in-room.

As with all acoustic transducers, we strongly recommend that you exercise good judgement when listening to your loudspeakers. High power/high SPL capable drivers such as Tempest can cause permanent hearing damage and actual hearing loss, if abused. Prolonged exposure to levels in excess of 110 dB can cause partial or full deafness. Be kind to your ears!

### 2.2 Mounting

Unlike most 15" subwoofer drivers, Tempest is fully rated for downfiring operation. The very long Xmax (16.4mm one way), combined with the mid-low Fs (18.8 Hz) and medium stiffness suspension (Vas of 317L) allows Tempest to operate in a downfiring mode with little appreciable loss in useable Xmax.

## 2.3 Room Gain

The room has a tremendous effect on the low-frequency performance of any loudspeaker system. This effect is generically referred to as room gain, although it is actually composed of two parts: boundary gain and pressure-vessel gain.

Boundary gain arises from the driver operating not in free space but in a constrained space. That is, the driver is typically referred to as operating in  $4\pi$  space free air, but  $\frac{1}{2}\pi$  space in-room. Each boundary cuts the total “space” in half. Thus the floor boundary cuts the space to  $2\pi$ , the side wall cuts the space to  $\pi$ , and the rear wall finishes reducing the space to  $\frac{1}{2}\pi$  (also referred to as eighth space).

Pressure vessel gain comes from the fact that, below a certain frequency, the room no longer supports standing waves; that is, the room is too small to contain a full wavelength. Contrary to legend, this does NOT mean the room cannot “reproduce” such waves! Rather, it means that the room is completely and uniformly pressurized by the input signal (we can’t call it a wave, since it’s not a full wave). This results in a gain in acoustic pressures in the room that grows as the frequency decreases (more gain for lower frequencies). Note that this effect is the primary reason one can get tremendous bass levels within a car; the gain starts at a very high frequency, thanks to the small size of the pressure vessel (car interior).

## 3 Designs

There are three basic sealed designs for Tempest: low Q ( $Q=0.577$ ), mid Q ( $Q=0.707$ ), and high Q ( $Q=0.9$ ). These three designs cover the range of “audiophile bass” ( $Q=0.577$ ), home theater/rock bass ( $Q=0.9$ ) and a combination of the two ( $Q=0.707$ ).

The actual design results are not presented in this application note; rather, we offer LspCAD files for use with the freeware version of LspCAD available at our website. This allows a much more in-depth look at the performance of the system, as well as custom tailoring of the room, amplifier, and crossover used with the design.

### 3.1 Low Q Design

The low Q design for Tempest ( $Q=0.577$ ) is a traditional Bessel alignment. This alignment provides the flattest group delay curve, while still providing a bit more flat bass extension over a critically damped alignment. Overall, the sonic character of this alignment is of neutral, natural bass, with very good extension and SPL capability. This alignment is well suited for all kinds of music, but excels at reproduction of acoustic bass signals (such as from acoustic string basses, cellos, tympanis, and organs).

The low Q design is a net 230L cabinet. It is stuffed with 64 ounces of polyfill. It’s external dimensions are 35” tall, 24” wide, and 24” deep. This includes the height from 4” tall legs. The Tempest is mounted on the bottom, downfiring. Three internal braces are used to stiffen the cabinet, and keep the widest panel span to a manageable 10.75” or less. Recommended building materials are void free plywood (such as marine ply, apple ply, or baltic birch), MDF, and particleboard, in that order.

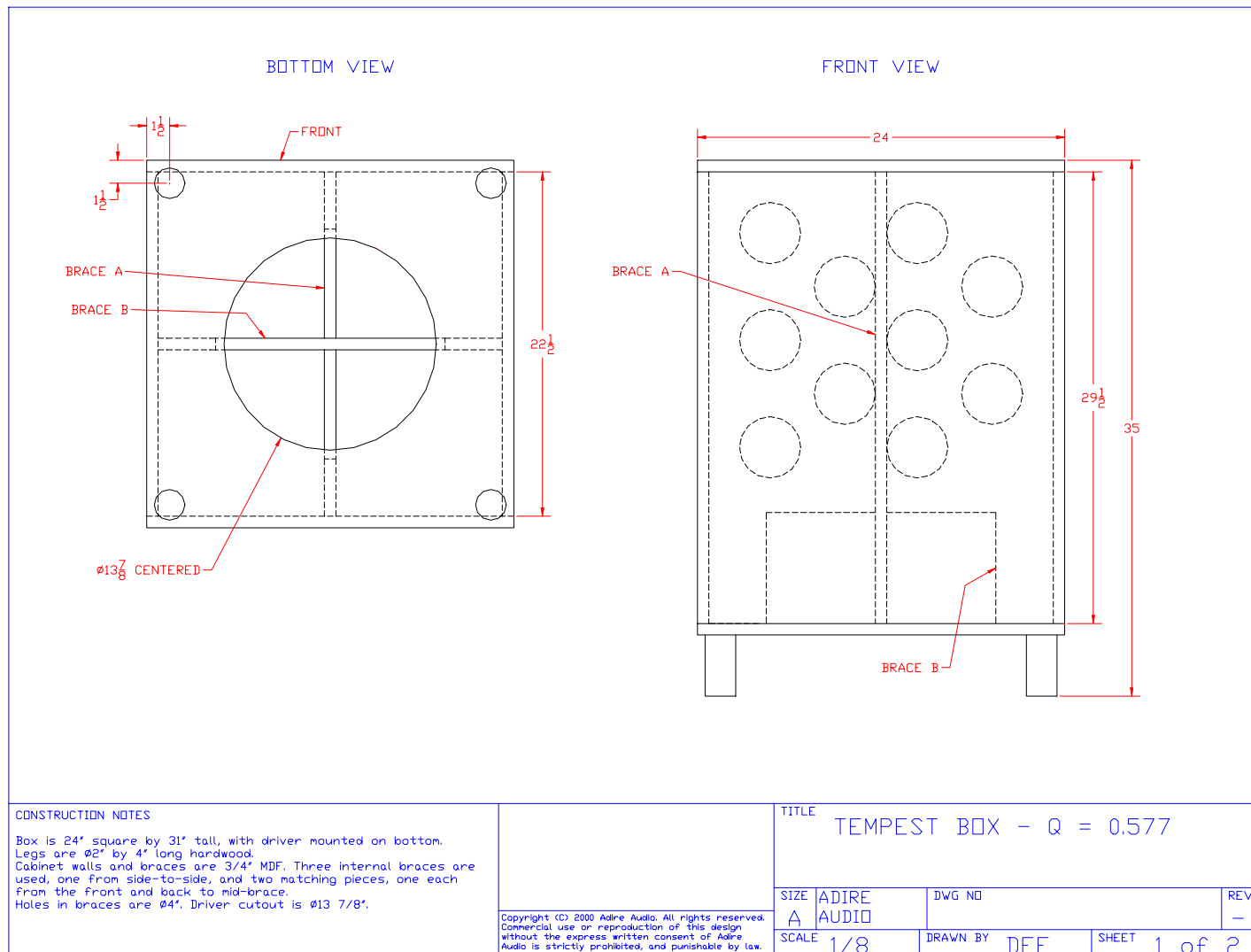

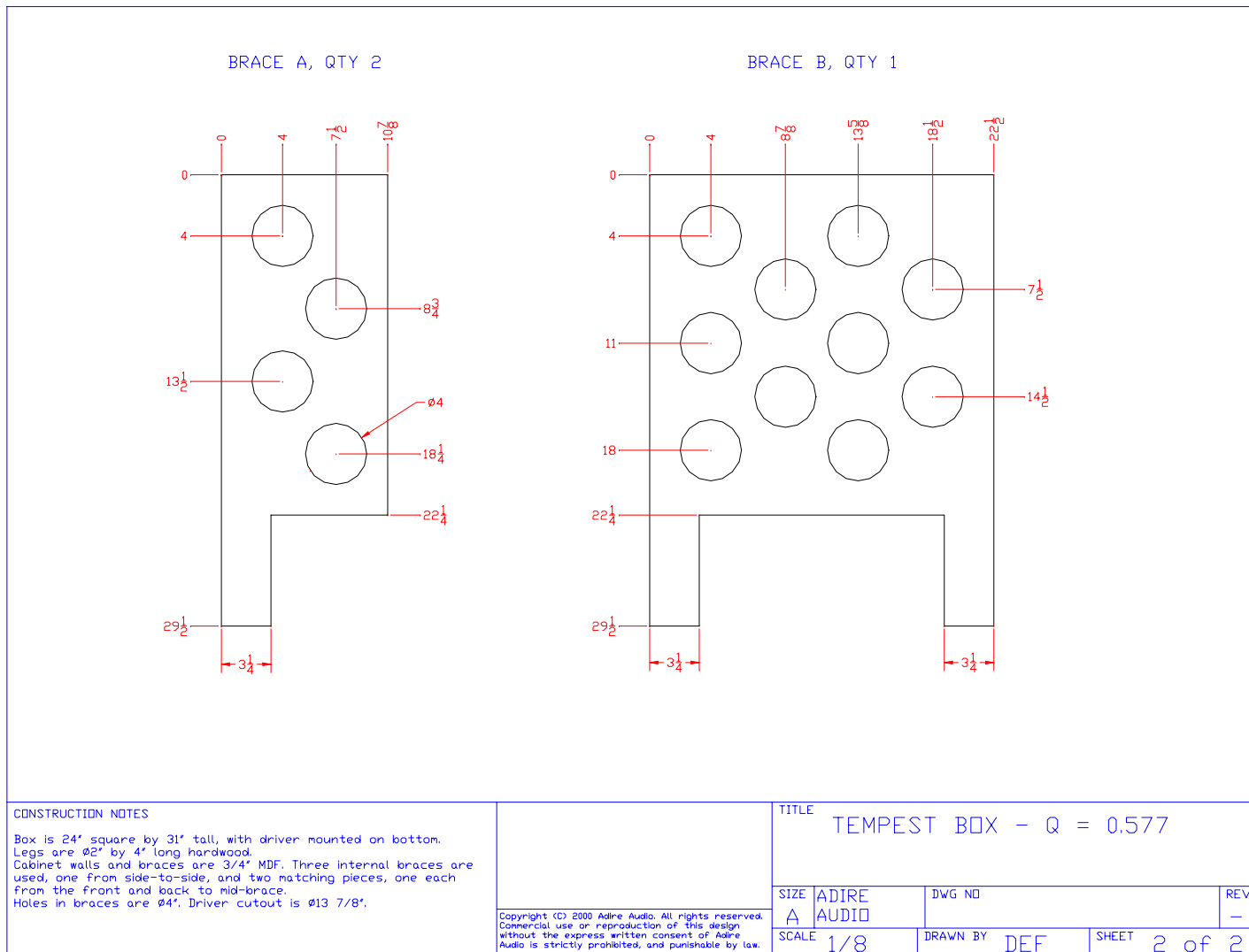

### **3.2 Mid Q Design**

The mid Q design for Tempest ( $Q=0.707$ ) is a traditional Butterworth alignment. This alignment provides the flattest bandwidth extension, without any peaks in the response. This alignment is arguably the most popular of all sealed alignments, because it promises extended bass response with good transient response. While not having the low group delay “tight sound” of the low Q design, nor the “mid bass punch” of the high Q design, the mid Q design is a very good compromise between the two, being equally adept at reproducing Handel or Hendrix.

The mid Q design is a net 122L cabinet. It is stuffed with 32 ounces of polyfill. It’s external dimensions are 25.5” tall, 21.5” wide, and 21.5” deep. This includes the height from 4” tall legs. The Tempest is mounted on the bottom, downfiring. Three internal braces are used to stiffen the cabinet, and keep the widest panel span to a very good 9.75” or less. Recommended building materials are void free plywood (such as marine ply, apple ply, or baltic birch), MDF, and particleboard, in that order.

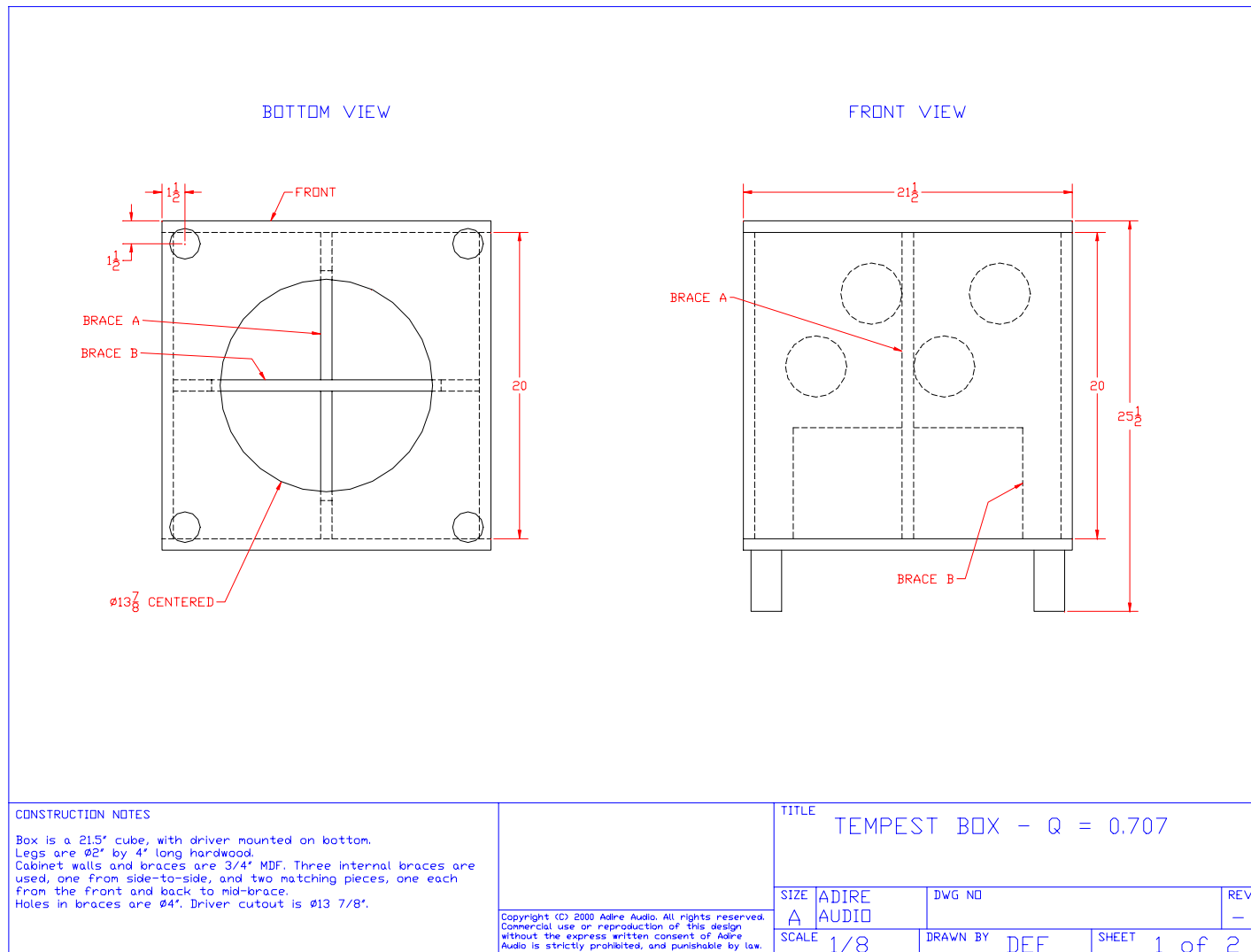

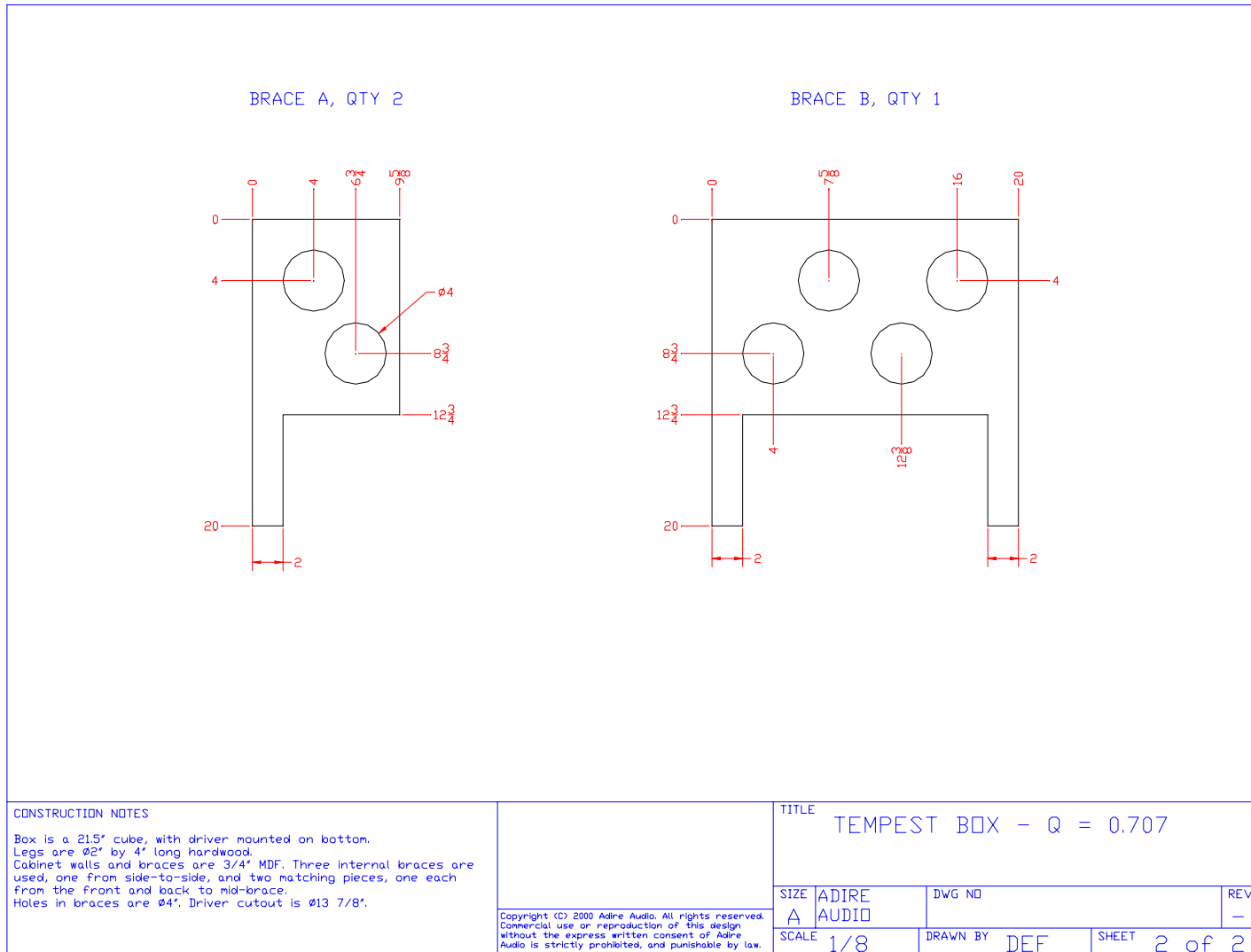



### **3.3 High Q Design**

The high Q design for Tempest ( $Q=0.9$ ) is a Chebychev alignment. This alignment provides a 0.6 dB peak in the response, and the least amount of bass extension of the three designs presented. The gain, however, is a very small box, and additional output in the midbass range between 30 and 50 Hz. This creates a sonic character that is well suited to home theater and rock music reproduction. While not as articulate as the other two alignments, the high Q alignment is often considered the most fun to listen to, simply because of the extra presence in the midbass.

As mentioned above, the high Q design utilizes a very small cabinet: 65L cabinet. It is stuffed with 16 ounces of polyfill. Its external dimensions are 22" tall, 18" wide, and 18" deep. This includes the height from 4" tall legs. The Tempest is mounted on the bottom, downfiring. Three internal braces are used to stiffen the cabinet, and keep the widest panel span to a very small 8" or less. Recommended building materials are void free plywood (such as marine ply, apple ply, or baltic birch), MDF, and particleboard, in that order.

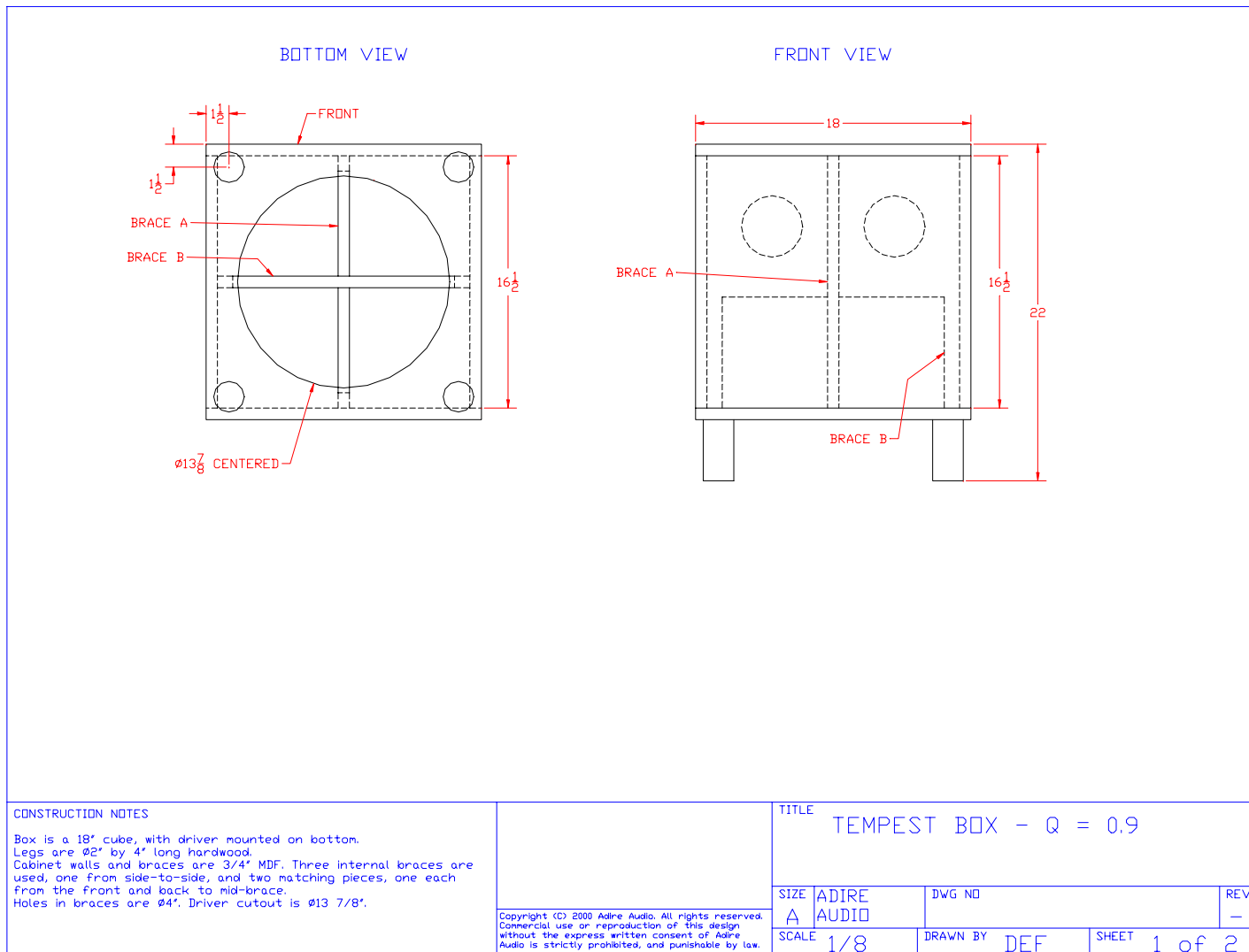

CONSTRUCTION NOTES

Box is a 18" cube, with driver mounted on bottom.  
 Legs are  $\phi 2"$  by 4" long hardwood.  
 Cabinet walls and braces are 3/4" MDF. Three internal braces are used, one from side-to-side, and two matching pieces, one each from the front and back to mid-brace.  
 Holes in braces are  $\phi 4"$ . Driver cutout is  $\phi 13 \frac{7}{8}"$ .

Copyright (C) 2000 Adire Audio. All rights reserved.  
 Commercial use or reproduction of this design without the express written consent of Adire Audio is strictly prohibited, and punishable by law.

TITLE TEMPEST BOX - Q = 0.9

SIZE A	ADIRE AUDIO	DWG NO	REV -
SCALE 1/8	DRAWN BY DEF	SHEET 1 of 2	

